

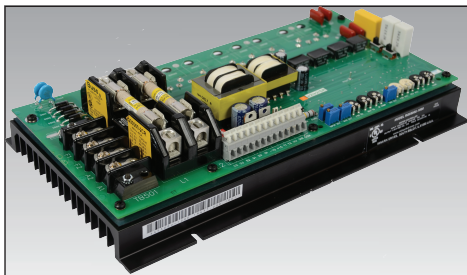

RG5500U



Isolated-Input, Four-Quadrant,
Regenerative SCR Drive

User's Manual

Copyright © 2004 by
Minarik Drives

All rights reserved. No part of this manual may be reproduced or transmitted in any form without written permission from Minarik Drives. The information and technical data in this manual are subject to change without notice. Minarik Drives and its Divisions make no warranty of any kind with respect to this material, including, but not limited to, the implied warranties of its merchantability and fitness for a given purpose. Minarik Drives and its Divisions assume no responsibility for any errors that may appear in this manual and make no commitment to update or to keep current the information in this manual.

Printed in the United States of America.

Safety Warnings



SHOCK
HAZARD



AVOID
HEAT



KEEP
DRY



AVOID
VIBRATION

- This symbol  denotes an important safety tip or warning. Please read these sections carefully prior to performing any of the instructions contained in that section.
- Have a qualified electrical maintenance technician install, adjust and service this equipment. Follow the National Electrical Code and all other applicable electrical and safety codes, including the provisions of the Occupational Safety and Health Act (OSHA), when installing equipment.
- Reduce the chance of an electrical fire, shock, or explosion by proper grounding, over-current protection, thermal protection, and enclosure. Follow sound maintenance procedures.



It is possible for a drive to run at full speed as a result of a component failure. Minarik strongly recommends the installation of a master switch in the main power input to stop the drive in an emergency.

Circuit potentials are at 115 VAC or 230 VAC above earth ground. Avoid direct contact with the printed circuit board or with circuit elements to prevent the risk of serious injury or fatality. Use a non-metallic screwdriver for adjusting the calibration trimpots. Use approved personal protective equipment and insulated tools if working on this drive with power applied.

Contents

Specifications	1
Dimensions	3
Installation	4
Mounting	4
Wiring	5
Shielding guidelines	6
Speed adjust potentiometer installation	7
Fusing	8
SCCR Rating	8
Cage-clamp terminal block	9
Connections	10
Motor connections	10
Power connections	10
Speed adjust potentiometer connections	11
Field output	14
Tachogenerator feedback (optional)	14
Signal follower (optional)	15
Polarity reversal switch (optional)	16
+15 and -15 terminals (optional)	17
DISABLE / ENABLE terminals	18
Slide switches (SW501–SW504)	19
DIP switches (SW505)	20
Operation	21
Before applying power	21
Startup	22
Uni-directional Operation	22
Bi-directional Operation (with speed adjust pot)	22
Voltage Follower	23
Current Follower	23
Starting and stopping methods	24
Line starting and line stopping	24

Line starting and line stopping	24
Automatic restart upon power restoration	25
Coast to a stop	25
Regenerative brake	25
Decelerate to minimum speed	27
Calibration	28
MINIMUM SPEED OUT (MIN OUT)	29
MAXIMUM SPEED OUT (MAX OUT)	29
FORWARD ACCELERATION (FWD ACC)	30
REVERSE ACCELERATION (REV ACC)	30
IR COMPENSATION (IR COMP)	31
FORWARD TORQUE (FWD TQ)	32
REVERSE TORQUE (REV TQ)	33
DEADBAND (DB)	35
TACHOGENERATOR (TACH)	36
CURRENT SIGNAL OFFSET	37
INPUT ADJUST (INPUT ADJ)	38
Application Notes	40
Connection to other Minarik devices	40
Optional speed adjust potentiometer connections	42
FWD-REV switch	42
FWD-MIN SPD-REV switch	43
Independent adjustable speeds	44
Independent forward and reverse speeds	45
Independent forward and reverse speeds with a FWD-STOP-REV switch	46
Troubleshooting	47
Before applying power	47
Replacement Parts	54
Unconditional Warranty	inside back cover

Illustrations

Figure 1. Four Quadrant Operation	.vi
Figure 2. RG5500U Dimensions	.3
Figure 3. Speed Adjust Potentiometer Installation	.7
Figure 4. Cage-Clamp Terminal Block	.8
Figure 5. RG5500U Connections	.11
Figure 6. Speed Adjust Potentiometer Connections	.12
Figure 7. Signal Follower Connections	.15
Figure 8. Polarity Reversal Switch Connections	.16
Figure 9. ± 15 VDC Supply Terminals	.17
Figure 10. DISABLE / ENABLE Terminals	.18
Figure 11. Slide Switch Settings	.19
Figure 12. Dip Switch Settings	.20
Figure 13. REGEN BRAKE Terminals	.26
Figure 14. Run / Decelerate to Minimum Speed Switch	.27
Figure 15. Typical FWD TQ, REV TQ, and IR COMP Settings	.34
Figure 16. Deadband Settings	.35
Figure 17. RG5500U Connection to Minarik DLC600	.40
Figure 18. RG5500U Connection to 200-0386A Limit Switch Logic Board	.41
Figure 19. Forward-Reverse Switch	.42
Figure 20. Forward-Minimum Speed-Reverse Switch	.43
Figure 21. Independent Adjustable Speeds (Forward Direction)	.44
Figure 22. Independent Forward and Reverse Speeds	.45
Figure 23. Independent Forward and Reverse Speeds with a Forward-Stop-Reverse Switch	.46

Tables

Table 1. SCCR Ratings	.8
Table 2. Field Output Connections	.14
Table 3. Replacement Parts	.54

Regenerative Drives

Most non-regenerative, variable speed DC drives control current flow to a motor in one direction. The direction of current flow is the same direction as the motor rotation.

Non-regenerative drives operate in Quadrant 1, and also in Quadrant 3 if the drive is reversible (see Figure 1, Page vi). Unless dynamic braking is used, non-regenerative drives cannot decelerate a load faster than coasting to a lower speed.

Regenerative drives operate in two additional quadrants: Quadrant 2 and Quadrant 4. In these quadrants, motor torque is in the opposite direction of motor rotation.

Regenerative drives can reverse a motor without contactors, switches, brake resistors, or inhibit plugs. They can also control an overhauling load and decelerate a load faster than it would take to coast to a lower speed.

The RG5500U is a full-wave, four-quadrant regenerative drive which provides smooth motoring and braking torque for SCR brush-type DC motors. The RG5500U controls motors from 1 through 5 Hp for single or bi-directional variable speed.

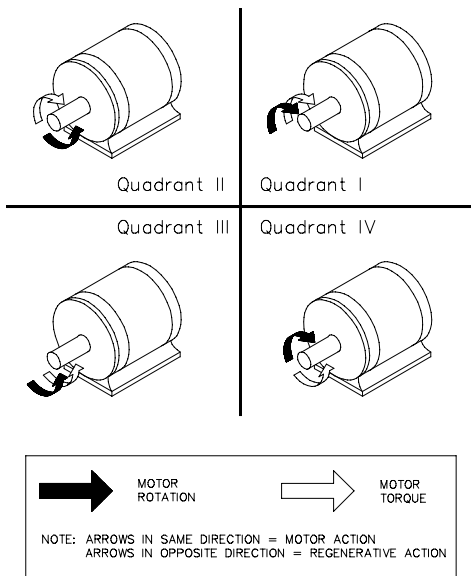

Figure 1. Four Quadrant Operation

Specifications

Model Number

RG5500U

Type	Open Chassis
AC Line Voltage	115 VAC or 230 VAC, $\pm 10\%$, 50Hz or 60 Hz, single phase
Line Fuse Rating	40 A (Buss Type SC-40 or equivalent)
Field Fuse Rating	3 A, fast acting
Horsepower Range @ 90 VDC Output	1 – 2.5 HP
Horsepower Range @ 180 VDC Output	1 – 5 HP
Maximum Armature Voltage Range @ 115 VAC Input	0–90 VDC
Maximum Armature Voltage Range @ 230 VAC Input	0–180 VDC
Minimum Speed Adjustment Range @ 115 VAC Input	0–60 VDC
Minimum Speed Adjustment Range @ 230 VAC Input	0–120 VDC
Maximum Peak (~ 2 sec) AC Input Current ‡	40A AC
Maximum Continuous AC Input Current ‡	30A AC
Maximum Peak (~ 2 sec) Armature Current ‡	30A DC
Maximum Continuous Armature Current ‡	27A DC
Field Voltage @ 115 VAC Input	50 VDC (F1 to L1) or 100 VDC (F1 to F2)
Field Voltage @ 230 VAC Input	100 VDC (F1 to L1) or 200 VDC (F1 to F2)
Form Factor @ Maximum Armature Voltage	1.37
Acceleration Time Range	0.5 – 8 seconds
Deceleration Time Range	0.5 – 8 seconds
Input Signal Ranges (grounded or ungrounded, isolated or non-isolated signal)	
Voltage Signal (narrow range)	–25 to +25 VDC
Voltage Signal (wide range)	–250 to +250 VDC
Current Signal (one of the following)	1–5 mADC; 4–20 mADC; 10–50 mADC

Recommended Speed Adjustment Potentiometer †	5 Kohms to 20 Kohms
Input Impedance	
Voltage Signal (S0 to S2)	25 Kohms
Voltage Signal (S0 to HV)	125 Kohms
Current Signal, 1–5 mADC	1 Kohms
Current Signal, 4–20 mADC	235 ohms
Current Signal, 10–50 mADC	100 ohms
Speed Regulation (% of base speed)	
Armature Feedback	1% or better
Tachogenerator Feedback	0.1%
Tachogenerator Feedback Voltage Range	7 VDC/1000 RPM to 50 VDC/1000 RPM
Weight	4.7 lb
Ambient Operating Temperature Range ‡	see notes
Vibration	0.5g max (0 – 50 Hz) 0.1g max (above 50 Hz)

Notes:

- † Drive shipped with 10 Kohm speed adjust potentiometer.
- ‡ 10°C–40°C when mounted flat (horizontally), or in an aluminum enclosure whose volume is between 5 and 8 cubic feet; 10°C–50°C when mounted upright (with heat sink fins vertical), or in an aluminum enclosure greater than 8 cubic feet. Open chassis SCR drives are rated at 55°C.

Dimensions

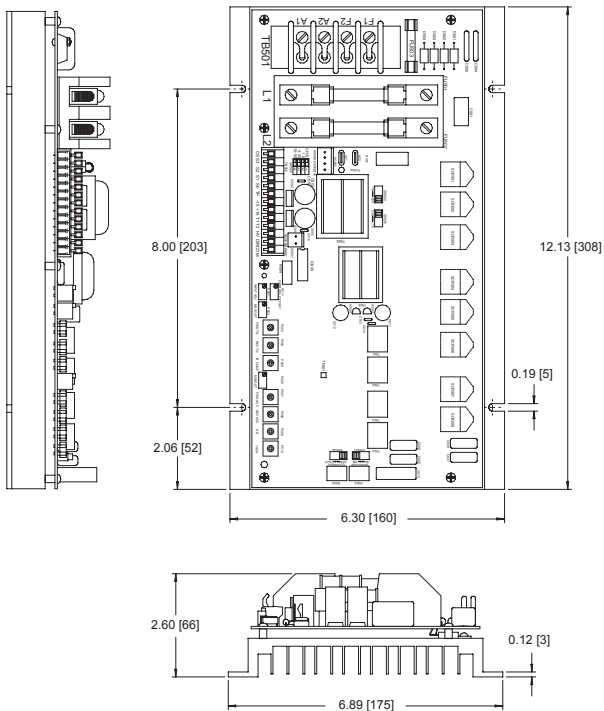

FOUR (4) MOUNTING SLOTS 0.19 [5] X 3.0 [8] DEEP
ALL DIMENSIONS IN INCHES [MILLIMETERS]

Figure 2. RG5500U Dimensions

Installation



Warning



Do not install, remove, or rewire this equipment with power applied. Failure to heed this warning may result in fire, explosion, or serious injury. Read and understand the Safety Warnings on page i before attempting installation.

The chassis must be earth grounded. Use a star washer beneath the head of at least one of the mounting screws to penetrate the anodized chassis surface and to reach bare metal.

Mounting

- Drive components are sensitive to electrostatic fields. Avoid direct contact with the circuit board. Hold drive by the chassis only.
- Protect the drive from dirt, moisture, and accidental contact. Provide sufficient room for access to the terminal block and calibration trimpots.
- Mount the drive away from heat sources. Operate the drive within the specified ambient operating temperature range.
- Prevent loose connections by avoiding excessive vibration of the drive.
- Mount drive with its board in either a horizontal or vertical plane. Four 0.19 in. (5 mm) wide slots in the chassis accept #8 pan head screws. Fasten either the large base or the narrow flange of the chassis to the subplate.

Wiring



Warning



Do not install, remove, or rewire this equipment with power applied. Failure to heed this warning may result in fire, explosion, or serious injury. Read and understand the Safety Warnings on page i before attempting installation.

Circuit potentials are at 115 or 230 VAC above ground. To prevent the risk of injury or fatality, avoid direct contact with the printed circuit board or with circuit elements.

Do not disconnect any of the motor leads from the drive unless power is removed or the drive is disabled. Opening any one motor lead may destroy the drive.

This product does not have internal solid state motor overload protection.

It does not contain speed-sensitive overload protection, thermal memory retention or provisions to receive and act upon signals from remote devices for over temperature protection.

If motor overload protection is needed in the end-use product, it needs to be provided by additional equipment in accordance with NEC standards.

Use 12 AWG wire for AC line voltage (L1 and L2) and motor armature (A1 and A2) wiring. Use 18 AWG wire for logic (S0, S1, S2, and S3) and 16 AWG for motor field (F1 and F2) wiring.

Shielding guidelines



Warning

Under no circumstances should power and logic leads be bundled together. Induced voltages can cause unpredictable behavior.

As a general rule, Minarik recommends shielding of all conductors.

If it is not practical to shield power conductors, Minarik recommends shielding all logic-level leads. If shielding logic leads is not practical, the user should twist all logic leads with themselves to minimize induced noise.

It may be necessary to earth ground the shielded cable. If noise is produced by devices other than the drive, ground the shield at the drive end. If noise is generated by a device on the drive, ground the shield at the end away from the drive. Do not ground both ends of the shield.

If the drive continues to pick up noise after grounding the shield, it may be necessary to add AC line filtering devices, or to mount the drive in a less noisy environment.

Speed adjust potentiometer installation



Warning

Be sure that the potentiometer tabs do not make contact with the potentiometer enclosure. Grounding the input will cause damage to the drive.

Install the circular insulating disk between the mounting panel and the 10K ohm speed adjust potentiometer (see Figure 3). Mount the speed adjust potentiometer through a 0.38-inch (10 mm) hole with the hardware provided. Twist the speed adjust potentiometer wires to avoid picking up unwanted electrical noise.

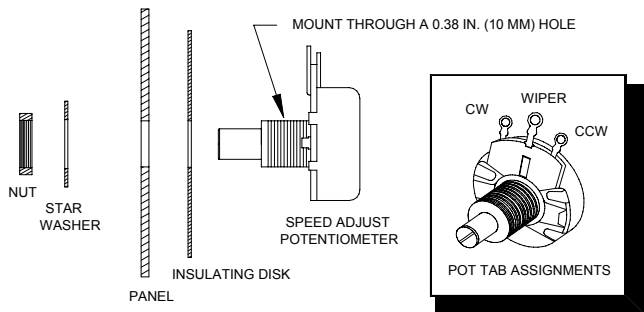

Figure 3. Speed Adjust Potentiometer Installation

Fusing

RG5500U drives have two 40A line fuses and one 3A field fuse installed. These fuses do not have to be resized. Replacement fuses may be ordered from your local Minarik Drives distributor. See Replacement Parts section on Page 54 for the fuse part numbers.

SCCR Rating

Short-circuit current rating (SCCR) is the maximum short-circuit current that the speed control can safely withstand when protected by a specific over-current protective device(s).

The rating for models rated more than 1 HP is tabulated below.

Drive Model No.	Short Circuit Current Rating		Types of Branch Circuit Protection		Maximum Rating of Overcurrent Protection
	Maximum Current, kA	Maximum Voltage, V			
RG5500U	10,000	240V	Non-time Delay K5 Fuse	Inverse Time Circuit Breaker	30A

Table 1. SCCR Rating

Cage-clamp terminal block

Logic connections to RG5500U are made to a cage-clamp terminal block. Refer to figure 4 for terminal block wiring procedure.

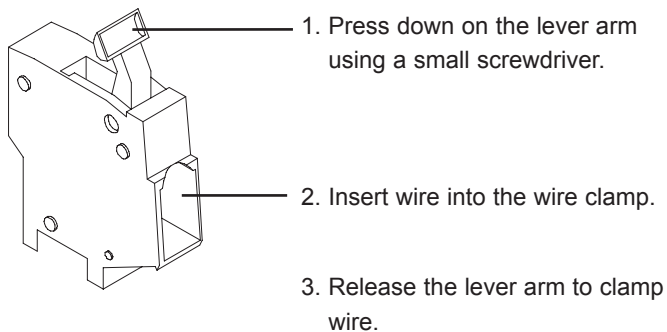

Figure 4. Cage-Clamp Terminal Block

Connections



Warning

Do not connect this equipment with power applied. Failure to heed this directive may result in fire or serious injury.

Minarik strongly recommends the installation of a master power switch in the voltage input line. The switch contacts should be rated at a minimum of 200% of motor nameplate current and 250 volts.

Motor connections

Minarik drives supply motor voltage from A1 and A2 terminals. It is assumed throughout this manual that, when A1 is positive with respect to A2, the motor will rotate clockwise (CW) while looking at the output shaft protruding from the front of the motor. If this is opposite of the desired rotation, simply reverse the wiring of A1 and A2 with each other.

Connect a DC motor to TB501 terminals A1 and A2 as shown in Figure 5 on Page 12. **Ensure that the motor voltage rating is consistent with the drive's output voltage.**

Power connections

Connect the AC line power leads to terminals L1 and L2, or to a double-throw, single-pole master power switch (recommended). See figure 5, page 12.

Speed adjust potentiometer connections

The motor can operate in one direction (unidirectional) or two directions (bidirectional) depending on how the speed adjust potentiometer is connected to the drive.

Connect the speed adjust potentiometer as shown in Figure 6(a) on Page 13 for bidirectional operation. The motor does not operate when the wiper is in the center position. Turning the wiper CW from the center causes the motor to rotate in one direction, while turning the wiper CCW from center causes rotation in the opposite direction.

Connect the speed adjust potentiometer as shown in Figure 6(b) on Page 13 for unidirectional operation in the forward direction.

Connect the speed adjust potentiometer as shown in Figure 6(c) on Page 13 for unidirectional operation in the reverse direction.

Refer to the Application Notes for additional speed adjust potentiometer connections.

Note: Make no connection to TP. It is used for test purposes only.

TACH FEEDBACK

* T1 should be pos (+) and T2 neg (-) when running in the forward direction (A1 is + and A2 is -).

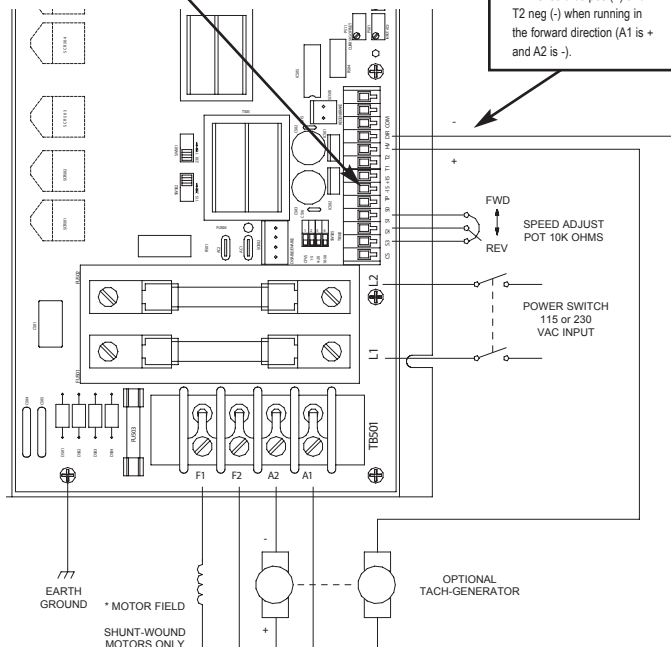

* Connection shown for 100 VDC or 200 VDC fields.

Figure 5. RG5500U Connections

(a) BIDIRECTIONAL

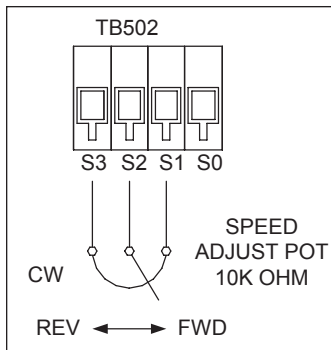

(b) UNIDIRECTIONAL (FWD)

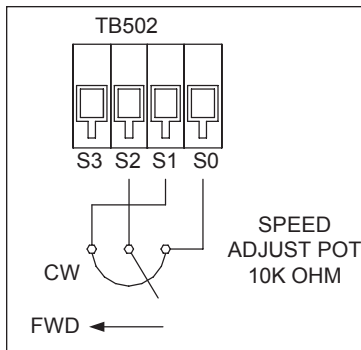

(c) UNIDIRECTIONAL (REV)

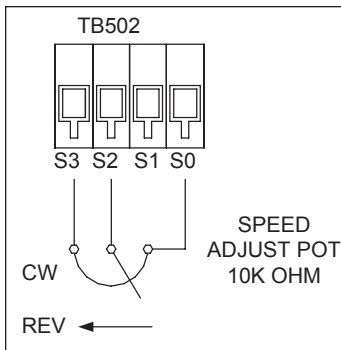

Figure 6. Speed Adjust Potentiometer Connections

Field output

The field output is for shunt wound motors only. Do not make any connections to the field output when using a permanent magnet motor. See Table 2 for field output connections.

Table 2. Field Output Connections

Line Voltage (VAC)	Approximate Field Voltage (VDC)	Field Connections
115	50	F1 and L1
115	100	F1 and F2
230	100	F1 and L1
230	200	F1 and F2

Tachogenerator feedback (optional)

Using tachogenerator feedback will improve speed regulation from approximately 1% of motor base speed to approximately 0.1% of motor base speed. RG5500U drives can use tachogenerators rated from 7 VDC per 1000 RPM to 50 VDC per 1000 RPM. Connect the tachogenerator to terminals T1 (+) and T2 (-) of terminal block TB502. See Figure 5 on Page 11 for tachogenerator connections.

NOTE: The RG5500U should receive a tachogenerator voltage that is positive (+) at T1 and negative (-) at T2, when the motor is running in the forward direction (A1 is + and A2 is -). If the tachogenerator is wired backwards, the drive may run at full speed.

Signal follower (optional)

Instead of using a speed adjust potentiometer, the drive may be wired to follow an external voltage or current input signal. See Figure 7 for signal follower connections and Figure 12 on Page 20 for DIP switch settings.

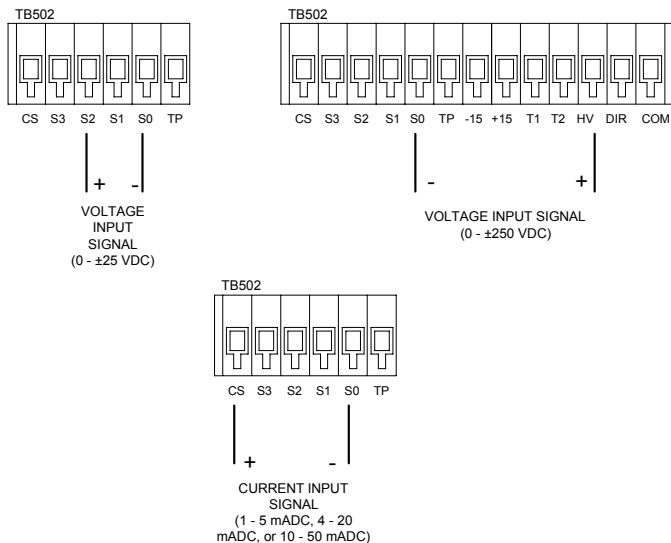

Figure 7. Signal Follower Connections

Polarity reversal switch (optional)

To reverse the output voltage polarity without changing the input polarity, connect DIR to COM. A single-pole, single-throw switch can be used as a polarity reversal switch. Close the switch to reverse the output voltage polarity. Open the switch to return the output voltage back to its original polarity. An open collector transistor may also be used to reverse. Apply a base-emitter voltage to reverse. See Figure 8 for both polarity reversal switch connections.

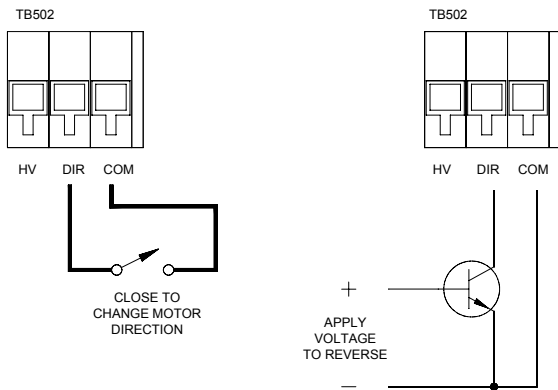

Figure 8. Polarity Reversal Switch Connections

+15 and -15 terminals (optional)



Warning

Do not short the +15 and -15 VDC terminals for any reason. Shorting these terminals may damage the drive. If you use relays, industrial PCs, or PLCs, Minarik recommends programming a delay before switching from one mode / direction to the other.

RG5000U drives can supply a regulated +15 VDC and -15 VDC signal (each sourcing 25 mA maximum) to isolated, external devices. These voltage supply terminals are located on terminal block TB502. See Figure 9.

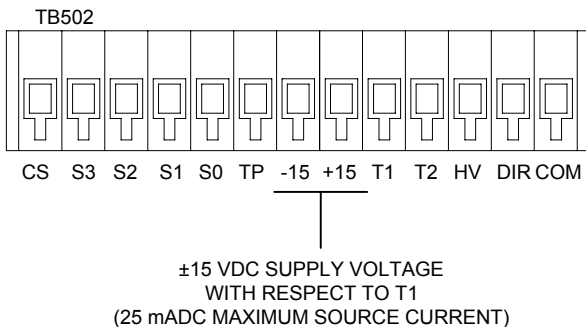

Figure 9. ±15 VDC Supply Terminals

DISABLE / ENABLE terminals



Warning

Do not short the +24 and COM terminals for any reason.
Shorting these terminals may damage the drive.

Each drive is assembled with the DISABLE / ENABLE terminals set to ENABLE (jumper on INH and -24V terminals). See Figure 10 for connections. These terminals must be connected for the motor to run.

To disable the drive, jumper the +24V and INH terminals. You may use a single-pole double-throw switch wired to SO502 instead of the jumper to select between ENABLE and DISABLE.

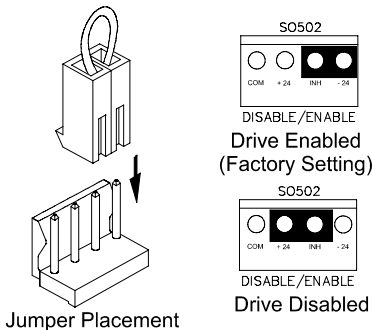

Figure 10. DISABLE / ENABLE Terminals

Slide switches (SW501–SW504)

Set all slide switches to their proper setting before applying power (see Figure 11).

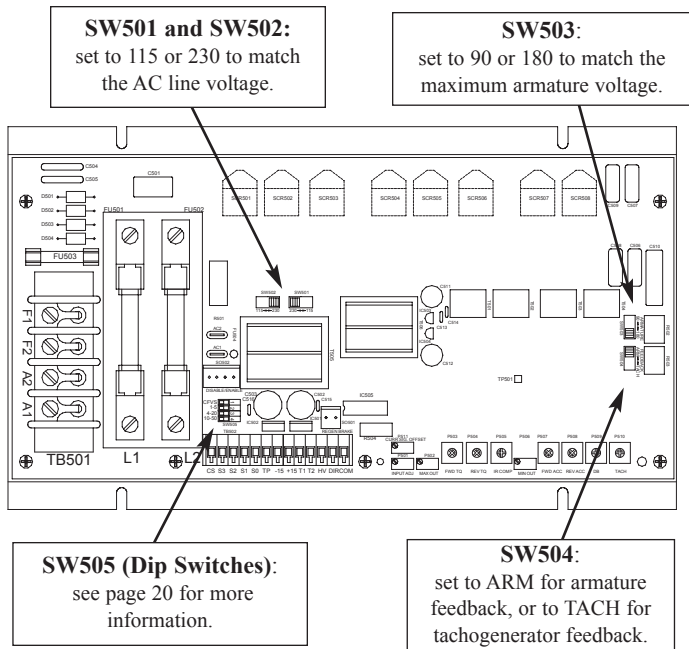
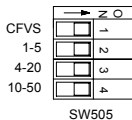

Figure 11. Slide Switch Settings

DIP switches (SW505)

Set SW505 to correspond to the voltage input signal or current input signal being used. See Figure 11 for dip switch location.

Use one of the four settings shown in Figure 12.



Set all DIP switches ON when a speed adjust potentiometer is used.

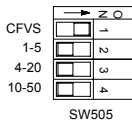

Set only DIP switch 1 (CFVS) ON when a voltage input signal is used.

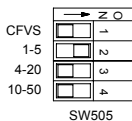

Set only DIP switch 2 ON when a 1–5 mADC current input signal is used.

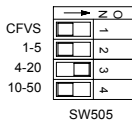

Set only DIP switch 3 ON when a 4–20 mADC current input signal is used.

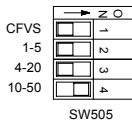

Set only DIP switch 4 ON when a 10–50 mADC current input signal is used.

Figure 12. Dip Switch Settings

Operation



Warning

Dangerous voltages exist on the drive when it is powered.
BE ALERT. High voltages can cause serious or fatal injury.

Before applying power

- Verify that no conductive material is present on the printed circuit board.
- Set all switches to their proper settings.
- Verify that the AC supply is properly balanced.

Startup

Uni-directional Operation

1. Set the speed adjust potentiometer to minimum (full CCW).
2. Apply AC line voltage.
3. Slowly turn the speed adjust potentiometer clockwise (CW).
If a voltage or current signal is used, slowly increase the voltage or current signal. The motor will accelerate as the potentiometer is turned CW, or the voltage or current signal is increased. Continue until the desired speed is reached.
4. Remove AC line voltage from the drive to coast the motor to a stop.

Bi-directional Operation (with speed adjust pot)

1. Set the speed adjust potentiometer to minimum (center position).
2. Apply AC line voltage.
3. Slowly turn the speed adjust potentiometer either clockwise for forward direction, or counterclockwise for reverse direction. The motor will accelerate as the potentiometer is turned. Continue until the desired speed is reached.
4. Remove AC line voltage from the drive to coast the motor to a stop.

Voltage Follower

1. If the drive is following a voltage signal, set the voltage signal to 0 VDC.
2. Slowly increase the voltage signal. The motor will accelerate as the signal is increased. Continue until the desired speed is reached.
3. Remove AC line voltage from the drive to coast the motor to a stop.

Current Follower

1. If the drive is following a current signal, set the current signal to minimum.
2. Slowly increase the current signal. The motor will accelerate as the signal is increased. Continue until the desired speed is reached.
3. Remove AC line voltage from the drive to coast the motor to a stop.

Starting and stopping methods



Warning

Regenerative braking, coasting to a stop, or decelerating to minimum speed is recommended for frequent stops and starts. Do not use any of these methods for emergency stopping. They may not stop a drive that is malfunctioning. Removing AC line power (both L1 and L2) is the only acceptable method for emergency stopping.

Certain Minarik drives (regenerative and non-regenerative) coast or brake to zero speed when the inhibit terminals are shorted to each other. IR COMP and CURRENT LIMIT (FWD TQ and REV TQ on regenerative drives) are still active while the drive is in inhibit mode.

NOTE: Minarik strongly recommends the installation of an emergency stop switch. The switch contacts should be rated at a minimum of 250 volts and 200% of maximum motor current.

Line starting and line stopping

When AC line voltage is applied to the drive, the motor accelerates to the set speed. When AC line voltage is removed, the motor coasts to a stop. Line starting and line stopping (applying and removing AC line voltage) is not necessary, and therefore not recommended for starting and stopping except for emergency situations.

Automatic restart upon power restoration

All drives automatically run to set speed when power is applied. Wiring a switch or latching relay onto the DISABLE / ENABLE terminal block allows you to apply AC line voltage to the drive without engaging the power circuitry.

Coast to a stop

To coast the motor to a stop without removing power to the drive, jumper the +24 and INH terminals on SO502. To restart the motor, jumper the INH and -24 terminals on SO502. (See Figure 10, page 18)

Regenerative brake

Short the REGEN BRAKE terminals to regeneratively brake the motor (see Figure 13 on page 26). Reopen the REGEN BRAKE terminals to accelerate the motor to set speed.

The REGEN BRAKE circuit bypasses both the MIN OUT circuit and the deceleration circuit. This causes the motor to stop rapidly when the REGEN BRAKE terminals are shorted. Braking torque is determined by the opposite-direction torque setting.

Minarik Drives offers two accessory plug harnesses for use with the REGEN BRAKE switch:

Minarik®

Part Number	Description
201-0024	Inhibit plug with 18 in. (46 cm) wires
201-0079	Inhibit plug with 36 in. (91 cm) wires

Twist inhibit plug wires and separate them from other power-carrying wires or sources of electrical noise. Use shielded cable if the inhibit plug wires are longer than 12 inches (30 cm). If shielded cable is used, ground only one end of the shield to earth ground. Do not ground both ends of the shield.

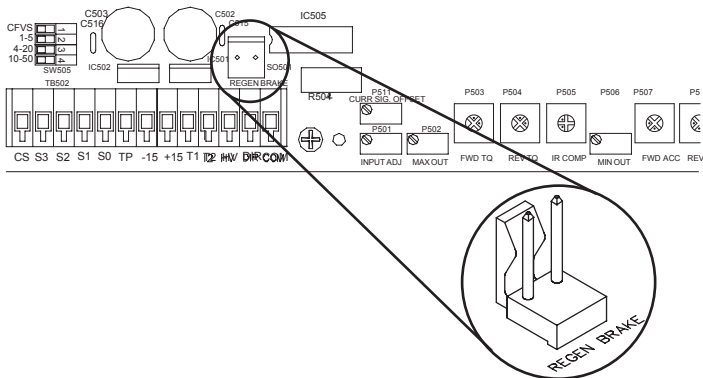

Figure 13. REGEN BRAKE Terminals

Decelerate to minimum speed

The circuit shown in Figure 14 may be used to decelerate a motor to a minimum speed. Closing the switch between S2 and S0 decelerates the motor from set speed to a minimum speed determined by the MIN OUT trimpot setting. If the MIN OUT trimpot is set full CCW, the motor decelerates to zero speed when the switch between S2 and S0 is closed. Calibrate the FWD ACC and REV ACC trimpots to control the acceleration and deceleration ramp. Set the switch to the RUN position to accelerate the motor to set speed

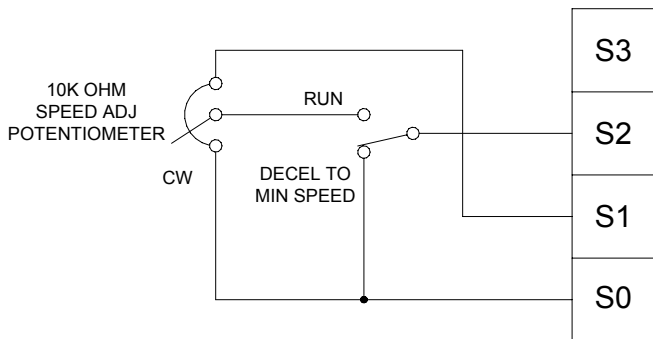

Figure 14. Run / Decelerate to Minimum Speed Switch

Calibration



Warning

Dangerous voltages exist on the drive when it is powered. When possible, disconnect the voltage input from the drive before adjusting the trimpots. If the trimpots must be adjusted with power applied, use insulated tools and appropriate personal protection equipment. BE ALERT. High voltages can cause serious or fatal injury.

Each drive is factory calibrated to its maximum current rating. Readjust the calibration trimpot settings to accommodate lower current rated motors.

All adjustments increase with clockwise rotation (CW), and decrease with counter-clockwise rotation (CCW). 25-turn trimpots click at the start and end points of rotation. Use a non-metallic screwdriver for calibration. Each trimpot is identified on the printed circuit board.

MINIMUM SPEED OUT (MIN OUT)

The MIN OUT setting determines the minimum speed when the speed adjust potentiometer, voltage input signal, or current input signal is set for minimum speed. It is factory set to zero speed.

The minimum speed feature applies only when the drive is operating in unidirectional mode.

To calibrate the MIN OUT trimmer pot, set the speed adjust potentiometer full CCW. If a voltage or current input signal is used, set the input signal to minimum. Adjust the 25-turn MIN OUT trimpot until the motor runs at the desired minimum speed.

MAXIMUM SPEED OUT (MAX OUT)

The MAX OUT setting determines the maximum motor speed when the speed adjust potentiometer, voltage input signal, or current input signal is set for maximum speed. It is factory set for maximum rated motor speed.

To calibrate the MAX OUT trimmer pot, set the speed adjust potentiometer full CW. If a voltage or current input signal is used, set the input signal to maximum. Adjust the 25-turn MAX OUT trimpot until the motor runs at the desired maximum speed.

Note: Check the MIN OUT and MAX OUT adjustments after recalibrating to verify that the motor runs at the desired minimum and maximum speeds.

FORWARD ACCELERATION (FWD ACC)

The FWD ACC setting determines the time it takes the motor to ramp to either a higher speed in the forward direction or a lower speed in the reverse direction, within the limits of available torque. The FWD ACC setting is factory set for its fastest forward acceleration time.

Turn the FWD ACC trimpot CW to increase the forward acceleration time and reverse deceleration time, and CCW to decrease the forward acceleration time and reverse deceleration time.

REVERSE ACCELERATION (REV ACC)

The REV ACC setting determines the time it takes the motor to ramp to either a higher speed in the reverse direction or a lower speed in the forward direction, within the limits of available torque. The REV ACC setting is factory set for its fastest reverse acceleration time.

Turn the REV ACC trimpot CW to increase the reverse acceleration time and forward deceleration time, and CCW to decrease the reverse acceleration time and forward deceleration time.

IR COMPENSATION (IR COMP)

The IR COMP (also known as Regulation) setting determines the degree to which motor speed is held constant as the motor load changes. It is factory set for optimum motor regulation.

Recalibrate the IR COMP setting when using a lower current rated motor. See Figure 15 on page 34, for typical IR COMP settings, or recalibrate using the following procedure:

1. Set the IR COMP trimpot to minimum (full CCW).
2. Rotate the speed adjust potentiometer until the motor runs at midspeed without load (for example, adjust to 900 RPM for an 1800 RPM motor). A hand held tachometer may be used to measure motor speed.
3. Load the motor armature to its full load armature current rating. The motor should slow down.
4. While keeping the load on the motor, rotate the IR COMP trimpot until the motor runs at the speed measured in step 2. If the motor oscillates (overcompensation), the IR COMP trimpot may be set too high (CW). Turn the IR COMP trimpot CCW to stabilize the drive.
5. Unload the motor.

FORWARD TORQUE (FWD TQ)



Warning

FWD TQ should be set to 150% of the drive nameplate current rating. Continuous operation beyond this rating may damage the motor. If you intend to operate beyond the rating, contact your Minarik representative for assistance.

The FWD TQ setting determines the maximum torque for accelerating and driving the motor in the forward direction. It also sets the maximum torque for decelerating the motor in the reverse direction. To recalibrate, refer to the recommended settings in Figure 15 on page 34, or use the following procedure:

1. With the power disconnected from the drive, connect a DC ammeter in series with the armature.
2. Set the FWD TQ trimpot to minimum (full CCW).
3. Set the speed adjust potentiometer, voltage input signal, or current input signal for maximum forward speed.
4. Carefully lock the motor armature. Be sure that the motor is firmly mounted.
5. Apply line power. The motor should be stopped.
6. Slowly adjust the FWD TQ trimpot CW until the armature current is 150% of the motor nameplate current rating.
7. Turn the speed adjust potentiometer (or voltage input signal or current input signal to zero, if used) CCW until the motor stops.
8. Remove line power.
9. Remove the stall from the motor.
10. Remove the ammeter in series with the motor armature if it is no longer needed.

REVERSE TORQUE (REV TQ)



Warning

REV TQ should be set to 150% of the motor nameplate current rating. Continuous operation beyond this rating may damage the motor. If you intend to operate beyond the rating, contact your Minarik representative for assistance.

The REV TQ setting determines the maximum torque for accelerating and driving the motor in the reverse direction. It also sets the maximum torque for decelerating in the forward direction. To recalibrate, refer to the recommended settings in Figure 15 on page 34, or use the following procedure:

1. With the power disconnected from the drive, connect a DC ammeter in series with the armature.
2. Set the REV TQ trimpot to minimum (full CCW).
3. Set the speed adjust potentiometer, voltage input signal, or current input signal for maximum reverse speed.
4. Carefully lock the motor armature. Be sure that the motor is firmly mounted.
5. Apply line power. The motor should be stopped.
6. Slowly adjust the REV TQ trimpot CW until the armature current is 150% of motor nameplate current rating.
7. Turn the speed adjust potentiometer (or voltage input signal or current input signal, to zero if used) CCW until the motor stops.
8. Remove line power.
9. Remove the stall from the motor.
10. Remove the ammeter in series with the motor armature if it is no longer needed.

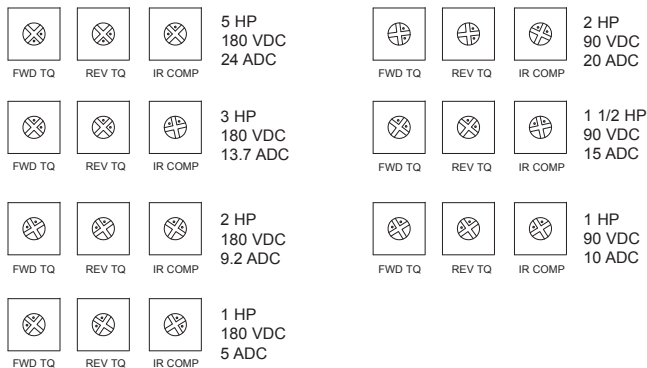

Figure 15. Typical FWD TQ, REV TQ, and IR COMP Settings (actual settings may vary with each application)

DEADBAND (DB)

The deadband trimmer potentiometer determines the time that will elapse between the application of current in one direction before current is applied in the opposite direction. It also affects the resistance that a motor has to changes in shaft position at zero speed by applying AC voltage to the motor armature.

Deadband is factory calibrated to approximately the 3 o'clock position for 60 Hz AC line operation. Recalibrate the deadband to the 9 o'clock position for 50 Hz AC line operation. If you hear motor noise (a humming sound), the deadband might be set too high. Turn the deadband trimpot CCW until the motor noise ceases. See Figure 16 for recommended deadband settings.

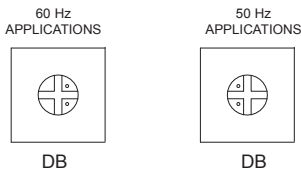

Figure 16. Deadband Settings

TACHOGENERATOR (TACH)

For use with tachogenerator feedback only

Calibrate TACH only when a tachogenerator is used. TACH, like IR COMP, determines the degree to which motor speed is held constant as the motor load changes.

To calibrate the TACH trimpot:

1. Connect the tachogenerator to T1 and T2. The polarity is “+” for T1 with respect to T2 when the motor running in the forward direction. A1 is “+” and A2 is “-” from the drive.
2. Set switch SW504 to ARM for armature feedback.
3. Set the speed adjust potentiometer full CW. Measure the armature voltage across A1 and A2 using a voltmeter.
4. Set the speed adjust potentiometer to 0 (zero speed).
5. Set SW504 to TACH for tachogenerator feedback.
6. Set the IR COMP trimpot full CCW.
7. Set the TACH trimpot full CW.
8. Set the speed adjust potentiometer full CW.
9. Adjust the TACH trimpot until the armature voltage is the same value as the voltage measured in step 3.

Check that TACH is properly calibrated. The motor should run at the same set speed when SW504 is set to either armature or tachogenerator feedback.

CURRENT SIGNAL OFFSET



Warning

This trimpot is set at the factory and should not need adjustment. Do not adjust this trimpot unless you are experiencing drift problems. Contact your Minarik representative before attempting adjustment, as improper calibration may have unpredictable results.

The RG5500U has a factory-set offset to guarantee stability in a stopped motor.

To calibrate CURR SIG OFFSET:

1. Ensure that input power is turned OFF.
2. Set the current input signal to zero.
3. Set the OFFSET trimpot to the approximate midrange or 50%.
4. Apply power and observe the motor shaft.
5. If the motor shaft drifts, or slowly rotates with no signal applied, adjust the CURR SIG OFFSET trimpot until the motor shaft stops. The direction and amount of trimpot adjustment depends on the direction of shaft rotation and connection of the motor leads.

INPUT ADJUST (INPUT ADJ)

The INPUT ADJ trimpot scales the voltage input signal.

Voltage Input Signal Calibration

1. Verify that DIP switch 1 (CFVS) on SW505 is ON. Set all other switches on SW505 to OFF. (see Figure 12 on page 20)
2. Set the INPUT ADJ trimpot to the approximate midrange.
3. Apply the minimum voltage input signal.
4. Adjust the MIN OUT trimpot until the motor runs at the desired minimum speed.
5. Apply the maximum voltage input signal.
6. Adjust the MAX OUT trimpot until the motor runs at the desired maximum speed.
7. If a higher maximum speed is desired, re-adjust the INPUT ADJ trimpot CW.
8. Repeat steps 3 through 7 until no further recalibration is necessary.

Current Input Signal Calibration

1. Verify that the correct DIP switch is ON (see Figure 12 on page 20).
2. Apply the minimum current input signal.
3. Adjust the MIN OUT trimpot until the motor runs at the desired minimum speed.
4. Apply the maximum current input signal.
5. Adjust the MAX OUT trimpot until the motor runs at the desired maximum speed.
6. Repeat steps 3 through 6 until no further recalibration is necessary.

Application Notes

Connection to other Minarik devices

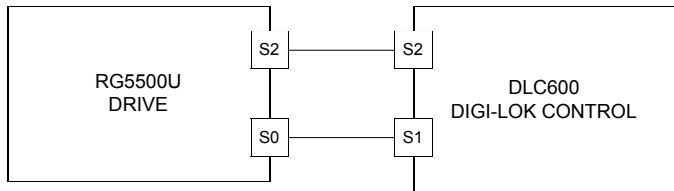

Figure 17. RG5500U Connection to Minarik DLC600

The RG5500UA can be connected to an optional 200-0386A limit switch logic board. The 200-0386A provides the logic interface between the regenerative drive and pushbutton stations, foot switches, or programmable controls. See figure 18 for RG5500UA connections to the 200-0386A limit switch logic board. For more information on Minarik's limit switch logic board, refer to User's Manual 250-0222 or the Minarik Product Catalog.

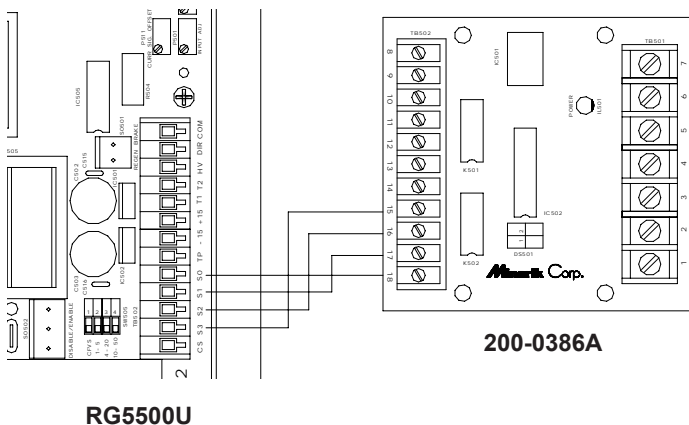

Figure 18. RG5500U Connection to 200-0386A Limit Switch Logic Board

Optional speed adjust potentiometer connections

FWD-REV switch

Use a single pole, two-position switch with a single speed adjust potentiometer to plug reverse a motor (Figure 19). The MIN OUT setting is in effect for either direction. Note: High currents exist when plug reversing a motor.

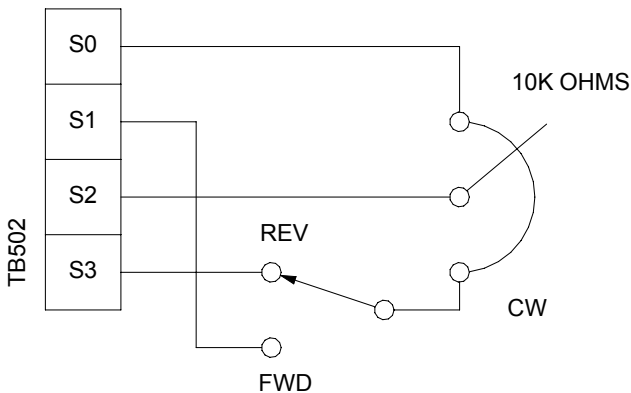

Figure 19. Forward-Reverse Switch

FWD-MIN SPD-REV switch

Use a single pole, three position switch with a single speed adjust potentiometer to stop a motor between reversals (Figure 20). Set the switch to the center position to decelerate the motor to minimum speed. Note: High currents exist when plug reversing a motor.

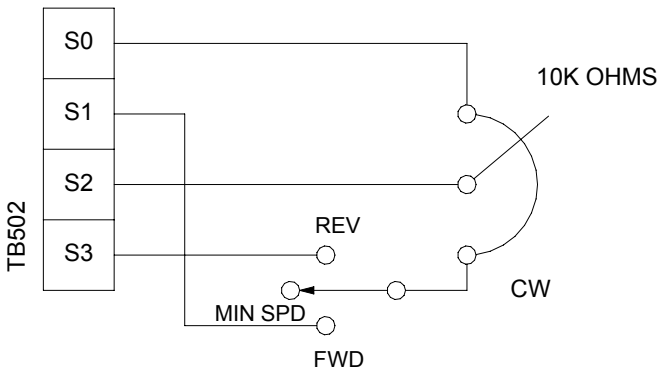

Figure 20. Forward-Minimum Speed-Reverse Switch

Independent adjustable speeds

Connect two speed adjust potentiometers with a single pole two position switch to select between two independent speeds shown in the forward direction (Figure 21). The speed adjust potentiometers can be mounted at two separate operating stations. Note: Total parallel resistance should be 10K ohms.

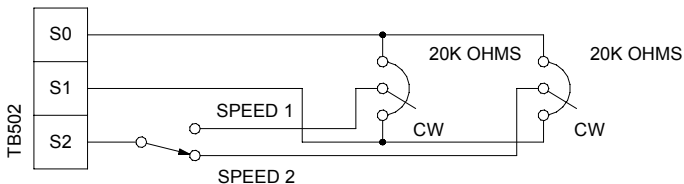

Figure 21. Independent Adjustable Speeds (Forward Direction)

Independent forward and reverse speeds

Connect two speed adjust potentiometers to select between independent forward and reverse speeds (Figure 22).

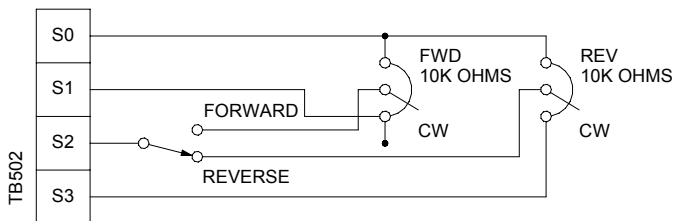

Figure 22. Independent Forward and Reverse Speeds

Independent forward and reverse speeds with a FWD-STOP-REV switch

Use a single pole, three position switch to stop the motor when the switch is in the center position (Figure 23).

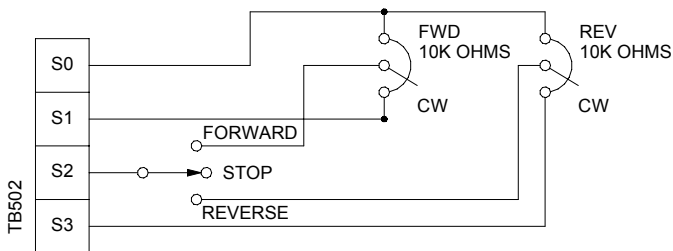

Figure 23. Independent Forward and Reverse Speeds with a Forward-Stop-Reverse Switch

Troubleshooting



Warning

Dangerous voltages exist on the drive when it is powered. When possible, disconnect the drive while troubleshooting. High voltages can cause serious or fatal injury.

Before applying power

Check the following steps before proceeding:

1. The deadband (DB) must be set approximately at the 3 o'clock position for 60 Hz AC line frequency or at 9 o'clock for 50 Hz AC line frequency. See figure 16 on page 35.
2. The motor must be rated for the drive's rated armature (all motors) and field outputs (shunt wound motors only).
3. Do not make any connections to F1 and F2 if using a permanent magnet motor.
4. Terminal block connections should be consistent with the connections shown in this manual.
5. Check that line fuses FU501 and FU502 are properly sized and not blown.
6. Check that field fuse FU503 is 3A and not blown.

For additional assistance, contact your local Minarik® distributor, or the factory direct: (800) MINARIK or (815) 624-5959
(815) 624-6960 fax

Problem	Possible Causes	Suggested Solutions
Field fuse blows	<ol style="list-style-type: none"><li data-bbox="366 207 591 273">1. Field fuse is the wrong size.<li data-bbox="366 313 565 415">2. Motor field is shorted to ground.<li data-bbox="366 523 632 554">3. F1 is shorted to F2.<li data-bbox="366 661 617 727">4. Motor cable is shorted to ground.<li data-bbox="366 872 607 971">5. Motor field leads are reversed with motor armature.	<ol style="list-style-type: none"><li data-bbox="670 207 936 273">1. Verify that the fuse is 3 A.<li data-bbox="670 313 933 448">2. Check if the motor field is shorted to ground. Replace motor if necessary.<li data-bbox="670 523 926 622">3. Check that F1 and F2 are not shorted together.<li data-bbox="670 661 923 833">4. Check that the motor cable is not shorted to ground. Replace cable if necessary.<li data-bbox="670 872 936 1004">5. Wire motor armature to A1 and A2; wire motor field to F1 and F2.

Problem	Possible Causes	Suggested Solutions
Line fuse blows	<ol style="list-style-type: none">1. Line fuses are the wrong size.2. Motor cable or armature is shorted to ground.3. Field circuit is open.4. Nuisance tripping caused by a combination of ambient conditions and high-current spikes (i.e. reversing).	<ol style="list-style-type: none">1. Check that line fuses are 40A.2. Check motor cable and armature for shorts.3. Send drive to Minarik Repair Department.4. Add a blower to cool the drive components; increase FWD TQ and REV TQ settings.
Motor runs too fast at maximum speed setting	<ol style="list-style-type: none">1. MIN OUT and MAX OUT settings are too high.2. Motor field connections are loose (shunt wound motors only).	<ol style="list-style-type: none">1. Recalibrate MIN OUT and MAX OUT.2. Check motor field connections.

Problem	Possible Causes	Suggested Solutions
Line fuse is not blown, but the motor does not run	<ol style="list-style-type: none"><li data-bbox="366 207 612 413">1. Speed adjust potentiometer, voltage input signal, or current input signal set to zero speed.<li data-bbox="366 452 622 764">2. Speed adjust potentiometer, voltage input signal, or current input signal not connected to drive input properly; connections are open.<li data-bbox="366 804 636 935">3. ENABLE terminals (INH and -24) are not jumpered on SO502.<li data-bbox="366 975 636 1040">4. REGEN BRAKE is jumpered.<li data-bbox="366 1106 636 1146">5. S2 is shorted to S0.	<ol style="list-style-type: none"><li data-bbox="670 207 928 379">1. Increase the speed adjust potentiometer, voltage, or current setting.<li data-bbox="670 452 940 584">2. Check connections to input. Verify that connections are not open.<li data-bbox="670 804 905 935">3. Jumper INH and -24 terminals on SO502 to enable the drive.<li data-bbox="670 975 917 1073">4. Remove jumper from REGEN BRAKE terminal.<li data-bbox="670 1106 876 1146">5. Remove short.

Problem	Possible Causes	Suggested Solutions
Line fuse is not blown, but the motor does not run (con't)	<ol style="list-style-type: none">6. Drive is in current limit. 7. Drive is not receiving AC line voltage. 8. Motor is not connected.	<ol style="list-style-type: none">6. Verify that motor is not jammed. Increase FWD TQ or REV TQ setting. They may be set too low. 7. Apply AC line voltage to L1 and L2. 8. Connect motor to A1 and A2.
Motor runs too slow or too fast	<ol style="list-style-type: none">1. Switches set incorrectly. 2. MIN OUT and MAX OUT not calibrated. 3. Motor field not properly connected (shunt wound motors only)	<ol style="list-style-type: none">1. Verify all switch settings. 2. Calibrate MIN OUT and MAX OUT. 3. Verify motor field connections.

Problem	Possible Causes	Suggested Solutions
Motor will not reach the desired speed	<ol style="list-style-type: none">1. MAX OUT setting is too low.2. INPUT ADJ setting is too low.3. IR COMP setting is too low.4. Motor is overloaded.	<ol style="list-style-type: none">1. Increase MAX OUT setting.2. Recalibrate INPUT ADJ setting.3. Increase the IR COMP setting.4. Check motor load. Resize the motor and drive if necessary.
Motor pulsates or surges under load	<ol style="list-style-type: none">1. IR COMP is set too high.2. Motor “bouncing” in and out of torque limit.	<ol style="list-style-type: none">1. Adjust the IR COMP setting slightly CCW until the motor speed stabilizes.2. Make sure motor is not undersized for load; adjust FWD TQ and REV TQ trimpots.

Problem	Possible Causes	Suggested Solutions
Motor does not reverse	<ol style="list-style-type: none">1. Bad switch connection to DIR and COM.2. Reversing circuit not working properly.	<ol style="list-style-type: none">1. Check switch connection to DIR and COM.2. Check reversing circuit by shorting DIR to COM with jumper wire.
Motor makes a humming or buzzing noise	Deadband setting is too high.	Turn deadband (DB) trimpot CCW until the noise stops.

Replacement Parts

Replacement parts are available from Minarik Drives and its distributors for this drive series.

Table 2. Replacement Parts

Model No.	Symbol	Description	Minarik P/N
RG5500U	C502, 503	470 uF, 50 V Capacitor	011-0056
	C510	.47 uF, 250 V Capacitor	010-0044
	C511, 512	220 uF, 25 V Capacitor	011-0027
	D501-504	1N5406 Diode	071-0007
	FH501	Fuse Holder	050-0061
	FU501, 502	40 A Fuse	050-0060
	FU504	1/2 A 250V Pico Fuse	050-0074
	R501	.002 ohm, 13 W Resistor	032-0133
	R502, 503	2K ohm, 5 W Resistor	032-0104
	SCR501-508	800 V, 65 A SCR	072-0059
	T505	DST-4-36 Transformer	230-0072
	T506	DST-2-36 Transformer	230-0066
	TB501	4 Terminal Block	160-0132
	TB502	Cage Clamp Terminal Block	160-0119

NOTES

NOTES

Unconditional Warranty

A. Warranty

Minarik Drives warrants that its products will be free from defects in workmanship and material for twelve (12) months or 3,000 hours, whichever comes first, from date of manufacture thereof. Within this warranty period, Minarik Drives will repair or replace, at its sole discretion, such products that are returned to Minarik Drives, 14300 De La Tour Drive, South Beloit, IL 61080 USA.

This warranty applies only to standard catalog products, and does not apply to specials. Any returns for special controls will be evaluated on a case-by-case basis. Minarik Drives is not responsible for removal, installation, or any other incidental expenses incurred in shipping the product to and from the repair point.

B. Disclaimer

The provisions of Paragraph A are Minarik Drives sole obligation and exclude all other warranties of merchantability for use, express or implied. Minarik Drives further disclaims any responsibility whatsoever to the customer or to any other person for injury to the person or damage or loss of property of value caused by any product that has been subject to misuse, negligence, or accident, or misapplied or modified by unauthorized persons or improperly installed.

C. Limitations of Liability

In the event of any claim for breach of any of Minarik Drives obligations, whether express or implied, and particularly of any other claim or breach of warranty contained in Paragraph A, or of any other warranties, express or implied, or claim of liability that might, despite Paragraph B, be decided against Minarik Drives by lawful authority, Minarik Drives shall under no circumstances be liable for any consequential damages, losses, or expense arising in connection with the use of, or inability to use, the product for any purpose whatsoever.

An adjustment made under warranty does not void the warranty, nor does it imply an extension of the original 12-month warranty period. Products serviced and/or parts replaced on a no-charge basis during the warranty period carry the unexpired portion of the original warranty only.

If for any reason any of the foregoing provisions shall be ineffective, Minarik Drives liability for damages arising out of its manufacture or sale of equipment, or use thereof, whether such liability is based on warranty, contract, negligence, strict liability in tort, or otherwise, shall not in any event exceed the full purchase price of such equipment.

Any action against Minarik Drives based upon any liability or obligation arising hereunder or under any law applicable to the sale of equipment or the use thereof, must be commenced within one year after the cause of such action arises.



MINARIK DRIVES

14300 De La Tour Drive
South Beloit, IL 61080

Phone: (800) MINARIK or (815) 624-5959

Fax: (815) 624-6960

www.minarikdrives.com

Document number 250-0225, Revision 5

Printed in the U.S.A – 05/13

\$11.00 U.S.A. – \$12.00 Outside U.S.A.